

NOZZLE SCHEDULE							
ITEM	SIZE	RATING	TYPE	MATL	PROJ IN	PROJ OUT	REMARKS
A	6"	N.P.T.	H.CPL	C.S.	STD.	STD.	EMERGENCY VENT OPENING
B	2"	N.P.T.	W.F.	C.S.	STD.	STD.	

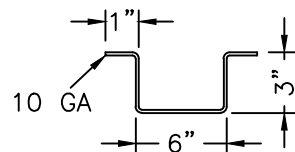

DETAIL A

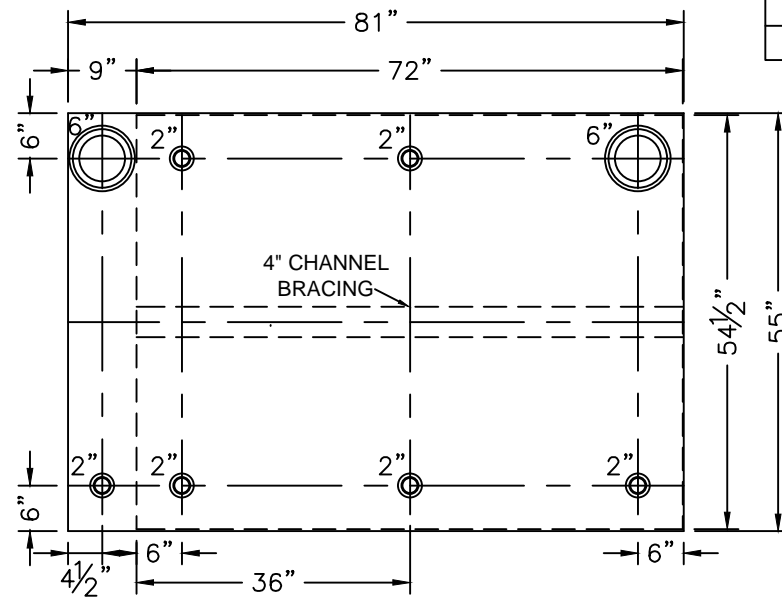

TOP VIEW

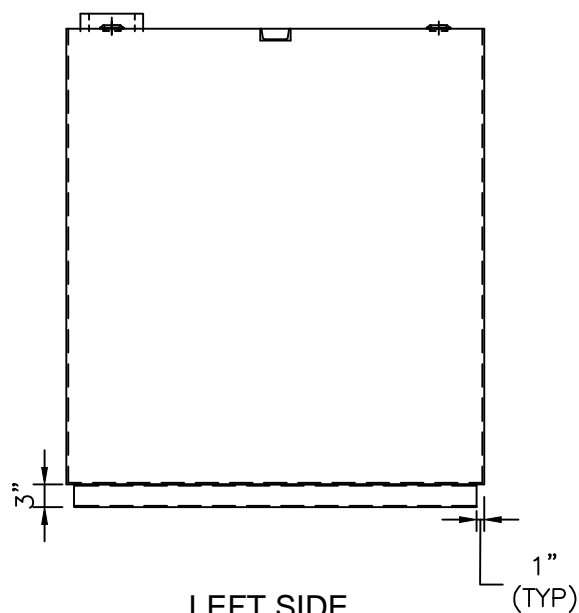

LEFT SIDE

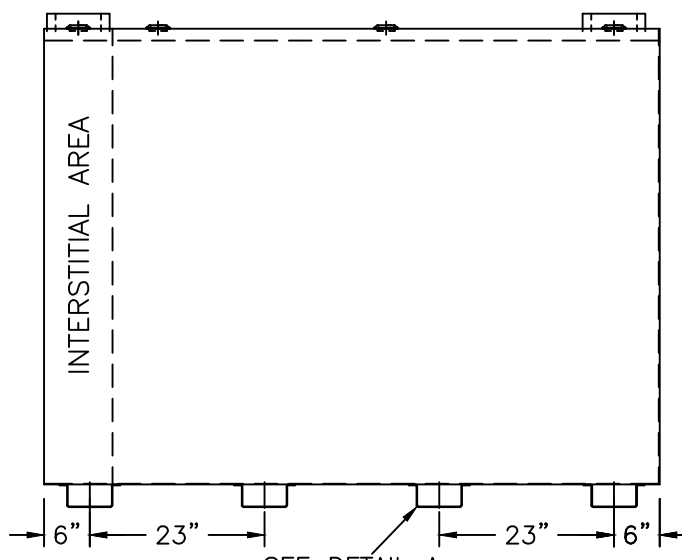

FRONT VIEW

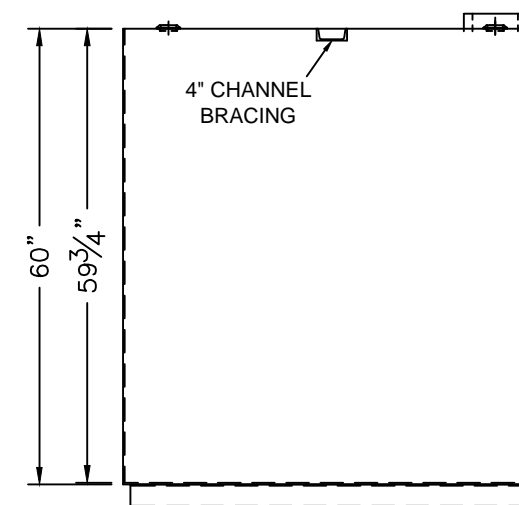

RIGHT SIDE

**NOTES:**

- A. Quantity:
- B. Material: H.R. Carbon Steel
- C. Inner tank: 10 GA.
- D. Outer tank 12GA w/ 10 Ga. Common Top
- E. Design Pressure: Atmospheric.
- F. Design Temperature: Ambient.
- G. Built & Labeled per U.L. Spec. #142.
- H. Air Test with Water & Soap Suds Solution.
- I. Interior: Remove Weld Slag (Ship Clean & Dry).
- J. Exterior: Gray primer included; see Sales Order for top coat.
- K. All Fittings to be Protected for Shipment.
- L. Customer to verify nozzle locations, sizes and quantities.

\*All pages of this Schedule A are incorporated by reference and are a part of the additional terms of the Master Terms & Conditions of Sale.  
[www.newberrytanks.com/masterterms.pdf](http://www.newberrytanks.com/masterterms.pdf)

**APPROVAL FOR CONSTRUCTION**  
 SCHEDULE A - MASTER TERMS & CONDITIONS OF SALE\*

- APPROVED AS DRAWN.
  - APPROVED WITH NOTED CHANGES, CONSTRUCTION WILL BE SCHEDULED WHEN SIGNED DRAWING AND CONFIRMED ORDER ARE RECEIVED.
- SIGNATURE \_\_\_\_\_  
 DATE: \_\_\_\_\_

**SALES ORDER #**



Phone: 870-735-4473 Fax: 870-735-3982

VESSEL DESCRIPTION:  
 1000 GALLON RECTANGULAR UL 142 DOUBLE WALL BULK STORAGE TANK

CUSTOMER:			P.O.#
DATE:	SCALE:	DWG.#	DRAWN BY: TC
		FTDBSW-1000	CHKD. BY: TB

This drawing may contain CONFIDENTIAL information and is intended only for the use of the specific individual(s) to which it is addressed.