

NOZZLE SCHEDULE

ITEM	SIZE	RATING	TYPE	MATL.	PROJ. IN	PROJ. OUT	REMARKS	NOTES
A	4"	N.P.T.	W.F.	C.S.	STD.	STD.	-	-
B	2"	N.P.T.	M.F.	C.S.	STD.	STD.	-	MONITORING PORT

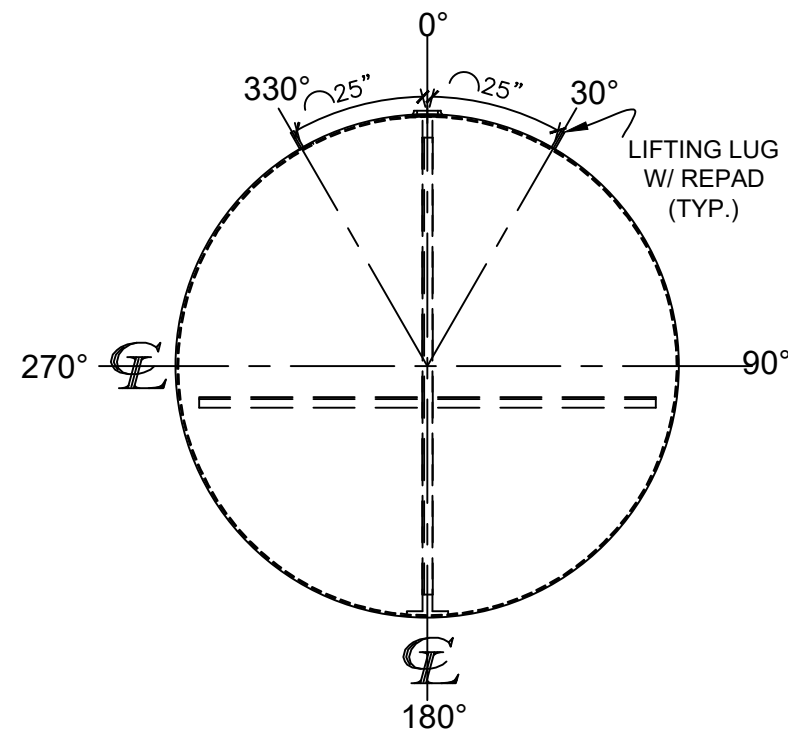

LEFT SIDE

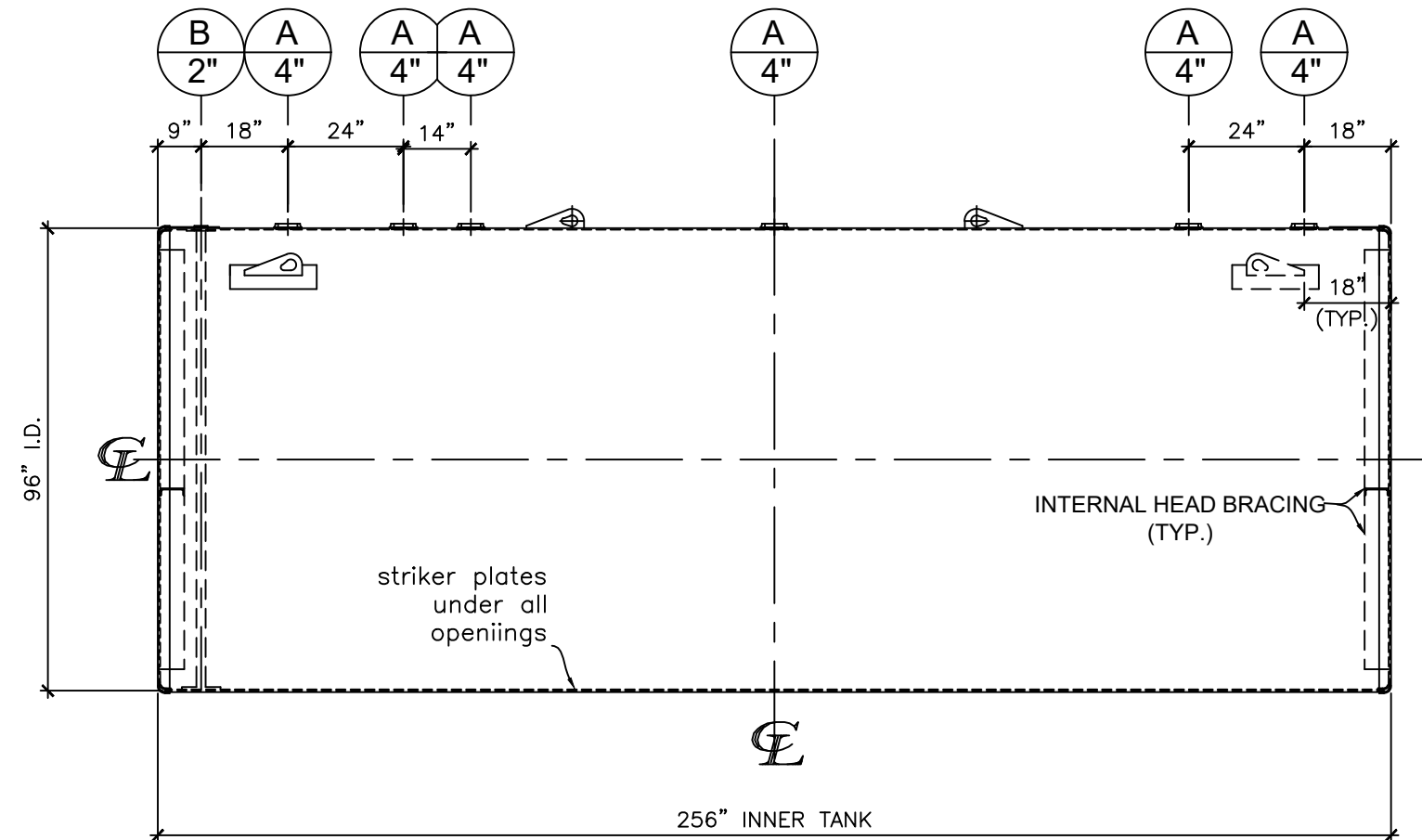

FRONT VIEW

NOTES:

- A. Quantity:
- B. Material: H.R. Carbon Steel.
- C. Design Pressure: Atmospheric.
- D. Design Temperature: Ambient.
- E. Built & labeled per U.L. #58, UL 1746 and ACT100 specs.
- F. Exterior: Blast & apply min.100 mils DFT Fiberglass.
- G. Seal welded striker plates under all openings.
- H. All fittings to be protected for shipment.
- I. Customer to verify nozzle sizes, locations and quantities.

*All pages of this Schedule A are incorporated by reference and are a part of the additional terms of the Master Terms & Conditions of Sale.
www.newberrytanks.com/masterterms.pdf

APPROVAL FOR CONSTRUCTION
 SCHEDULE A - MASTER TERMS &
 CONDITIONS OF SALE*

- APPROVED AS DRAWN.
 - APPROVED WITH NOTED CHANGES, CONSTRUCTION WILL BE SCHEDULED WHEN SIGNED DRAWING AND CONFIRMED ORDER ARE RECEIVED.
- SIGNATURE: _____
 DATE: _____

SALES ORDER#



Phone: 870-735-4473 Fax: 870-735-3982

VESSEL DESCRIPTION:

8000 Gallon 96" I.D. x 21'-4" O.A.L. Double Wall ACT-100 Tank

CUSTOMER:		P.O.#	
DATE:	SCALE:	DWG.#	DRAWN BY: TC
-	-	NB08000DWA096250	CHKD. BY:

This drawing may contain CONFIDENTIAL information and is intended only for the use of the specific individual(s) to which it is addressed.