

DETAIL A

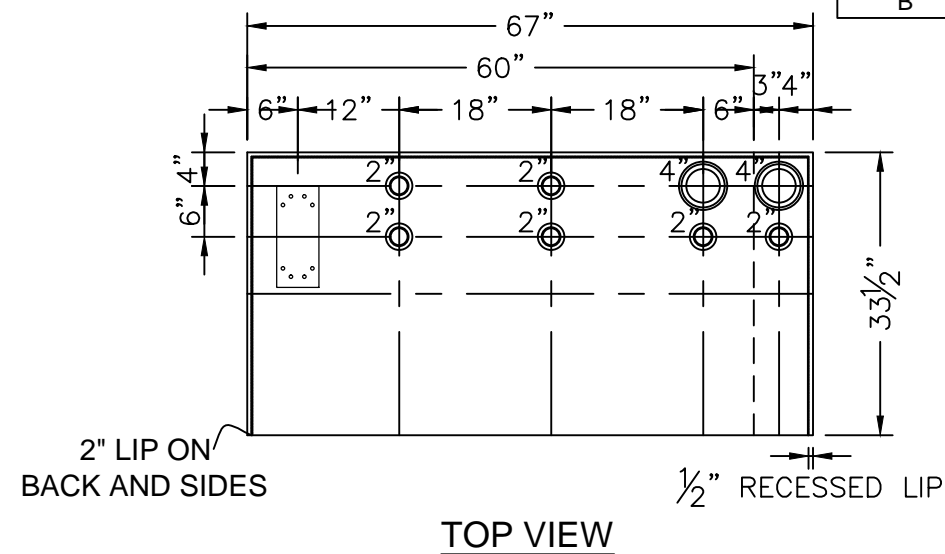

TOP VIEW

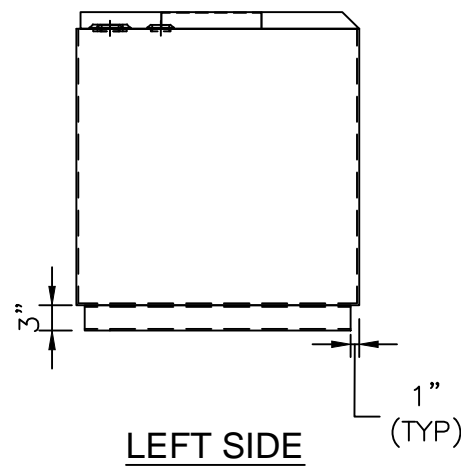

LEFT SIDE

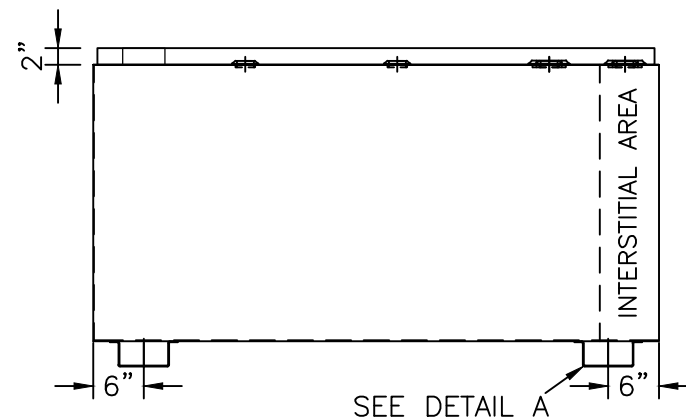

FRONT VIEW

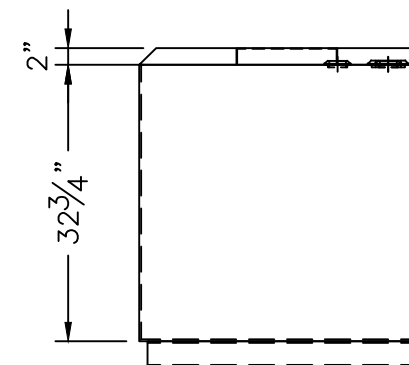

RIGHT SIDE

NOZZLE SCHEDULE							
ITEM	SIZE	RATING	TYPE	MATL	PROJ IN	PROJ OUT	REMARKS
A	4"	N.P.T.	W.F.	C.S.	STD.	STD.	EMERGENCY VENT OPENING
B	2"	N.P.T.	W.F.	C.S.	STD.	STD.	

NOTES:

- A. Quantity:
- B. Material: H.R. Carbon Steel
- C. Tank: 12 GA w/ 10 GA Common Top
- D. Design & Operating Pressure: Atmospheric.
- E. Design & Operating Temperature: Ambient.
- F. Tank to be Built & Labeled per U.L. Spec. #142.
- G. Tank to Bear Manufacturers & U.L. Labels Only.
- H. Tank to be Air Tested with Water & Soap Suds Solution.
- I. Interior: Remove Weld Slag (Ship Clean & Dry).
- J. Exterior: Gray primer included; see Sales Order for top coat.
- K. All Fittings to be Protected for Shipment.
- L. Customer has the Responsibility to Verify All Dimensions.

*All pages of this Schedule A are incorporated by reference and are a part of the additional terms of the Master Terms & Conditions of Sale.
www.newberrytanks.com/masterterms.pdf

APPROVAL FOR CONSTRUCTION
 SCHEDULE A - MASTER TERMS & CONDITIONS OF SALE*

- APPROVED AS DRAWN.
 - APPROVED WITH NOTED CHANGES, CONSTRUCTION WILL BE SCHEDULED WHEN SIGNED DRAWING AND CONFIRMED ORDER ARE RECEIVED.
- SIGNATURE _____
 DATE: _____

SALES ORDER #

 Phone: 870-735-4473 Fax: 870-735-3982

VESSEL DESCRIPTION:
 280 GALLON RECTANGULAR UL 142 DOUBLE WALL BENCH TOP TANK

CUSTOMER: _____ P.O.# _____

DATE: _____ SCALE: _____ DWG.# FTDBSB-0280 DRAWN BY: TC
 CHKD. BY: TB

This drawing may contain CONFIDENTIAL information and is intended only for the use of the specific individual(s) to which it is addressed.