

**NOZZLE SCHEDULE**

ITEM	SIZE	RATING	TYPE	MATL	REMARKS	NOTES
A	3"	N.P.T.	W.F.	C.S.	PRIMARY EMERGENCY VENT	
B	3"	N.P.T.	CPL	C.S.	SECONDARY EMERGENCY VENT	
C	2"	N.P.T.	PIPE	C.S.	INTERSTICE MONITOR	
D	2"	N.P.T.	W.F.	C.S.		

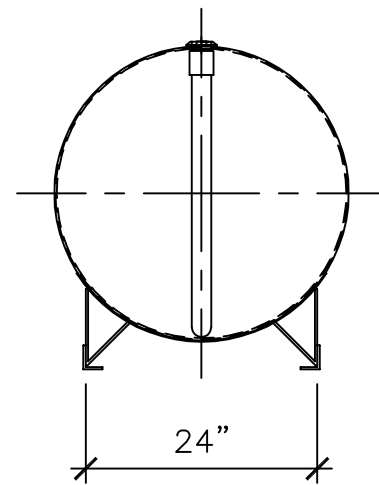

**LEFT SIDE**

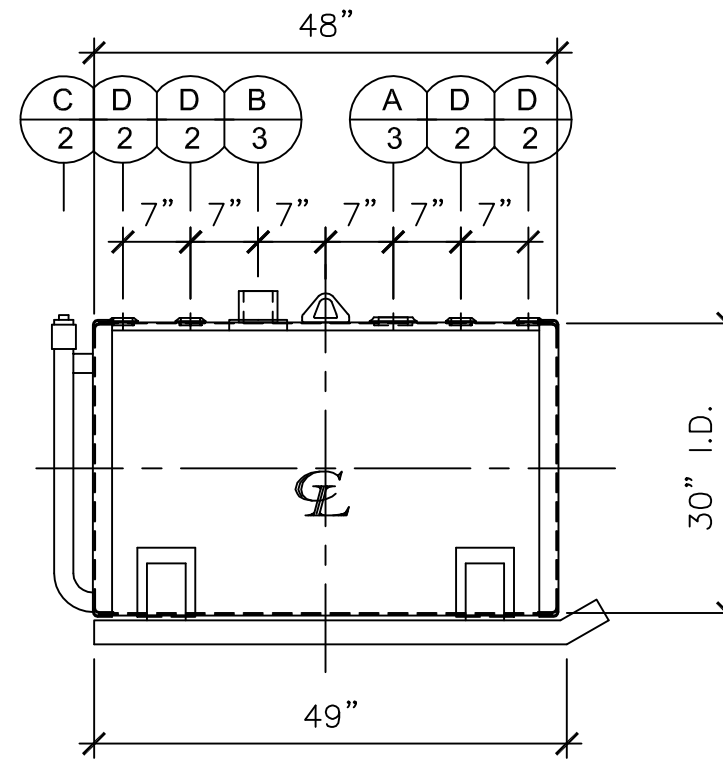

**FRONT VIEW**

**NOTES:**

- A. Quantity:
- B. Material: H.R. Carbon Steel.
- C. Design Pressure: Atmospheric.
- D. Design Temperature: Ambient.
- E. Built & Labeled per U.L. Spec. #142.
- F. Air Test with Water & Soap Suds Solution.
- G. Interior: Remove Weld Slag (Ship Clean & Dry).
- H. Exterior: Gray primer included; see Sales Order for top coat.
- I. All Fittings to be Protected for Shipment.
- J. Customer to verify nozzle locations, sizes and quantities.
- K. Saddles/skids may require shimming or grouting during installation.

\*All pages of this Schedule A are incorporated by reference and are a part of the additional terms of the Master Terms & Conditions of Sale.  
[www.newberrytanks.com/masterterms.pdf](http://www.newberrytanks.com/masterterms.pdf)

**APPROVAL FOR CONSTRUCTION**  
 SCHEDULE A - MASTER TERMS & CONDITIONS OF SALE\*

- APPROVED AS DRAWN.
- APPROVED WITH NOTED CHANGES, CONSTRUCTION WILL BE SCHEDULED WHEN SIGNED DRAWING IS RECEIVED.

SIGNATURE \_\_\_\_\_  
 DATE: \_\_\_\_\_

**SALES ORDER#**



Phone: 870-735-4473 Fax: 870-735-3982

VESSEL DESCRIPTION:

**150 Gallon 30" I.D. x 4'-0" O.A.L. Double Wall Skid Tank**

CUSTOMER: -		P.O.#	
DATE: -	SCALE:	DWG.# NB00150DWS03012G	DRAWN BY: GP
		CHKD. BY:	

This drawing may contain CONFIDENTIAL information and is intended only for the use of the specific individual(s) to which it is addressed.