

NOZZLE SCHEDULE							REMARKS
ITEM	SIZE	RATING	TYPE	MATL.	PROJ. IN	PROJ. OUT	
A	6"	N.P.T.	H.CPL.	C.S.	STD.	STD.	PRIMARY EMERGENCY VENT OPENING
B	6"	N.P.T.	H.CPL.	C.S.	STD.	STD.	SECONDARY EMERGENCY VENT OPENING
C	2"	N.P.T.	W.F.	C.S.	STD.	STD.	

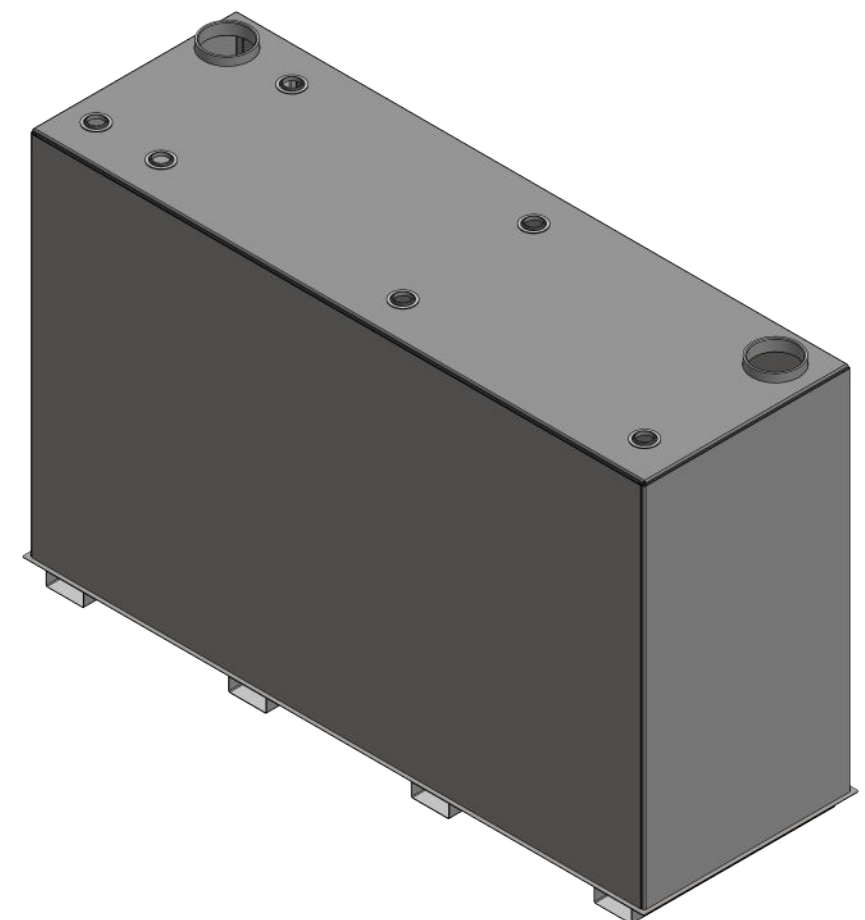
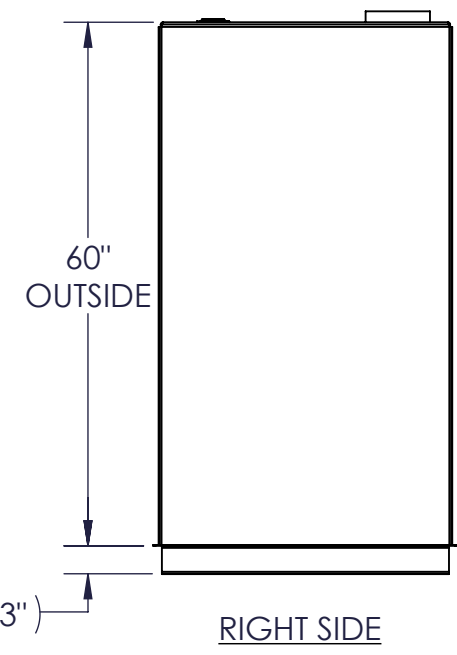
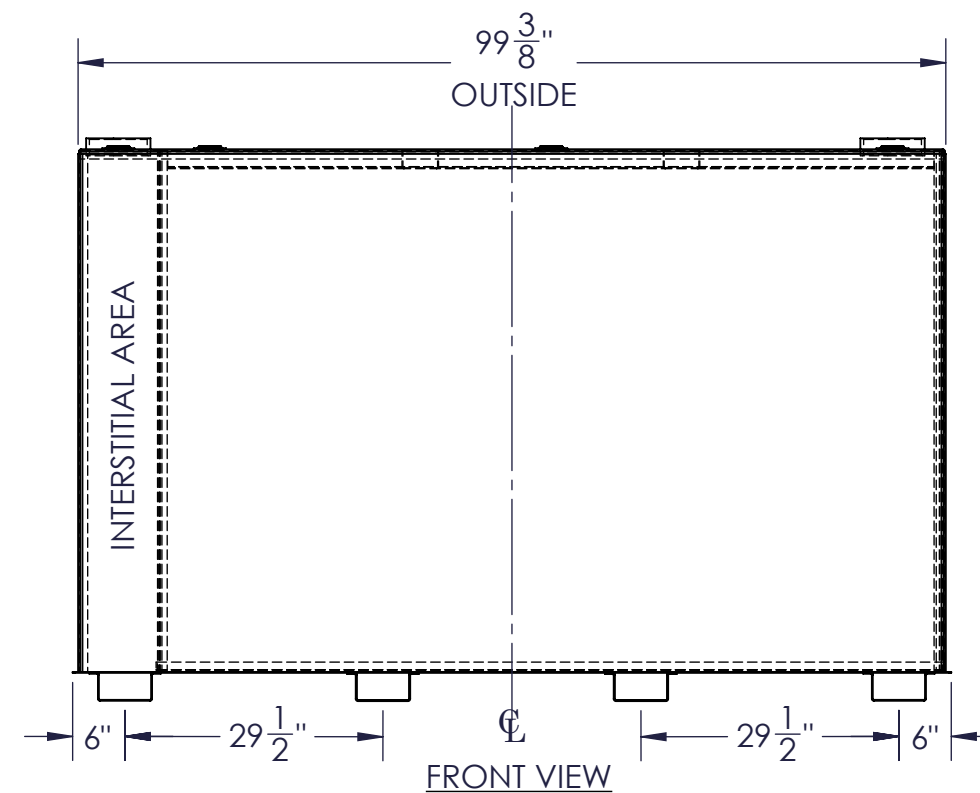
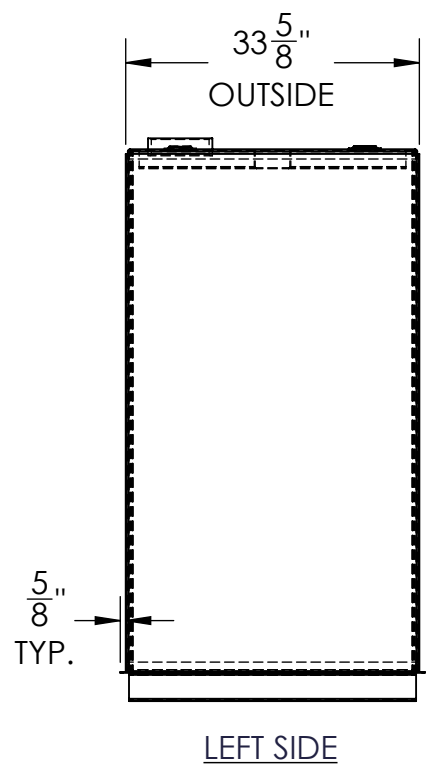

- NOTES:
- A. MATERIAL: H.R. CARBON STEEL
  - B. DESIGN & OPERATING PRESSURE: ATMOSPHERIC.
  - C. DESIGN & OPERATING TEMPERATURE: AMBIENT.
  - D. TANK TO BE BUILT & LABELED PER U.L. SPEC. #142.
  - E. TANK TO BEAR MANUFACTURERS & U.L. LABELS ONLY.
  - F. TANK TO BE AIR TESTED WITH WATER & SOAP SUDS SOLUTION.
  - G. INTERIOR: REMOVE WELD SLAG (SHIP CLEAN & DRY).
  - H. EXTERIOR: GRAY PRIMER INCLUDED; SEE SALES ORDER FOR TOP COAT.
  - I. ALL FITTINGS TO BE PROTECTED FOR SHIPMENT.
  - J. CUSTOMER HAS THE RESPONSIBILITY TO VERIFY ALL DIMENSIONS.

APPROVAL FOR CONSTRUCTION  
SCHEDULE A - MASTER TERMS &  
CONDITION OF SALE\*

APPROVED AS DRAWN.

APPROVED WITH NOTED CHANGES,  
CONSTRUCTION WILL BE SCHEDULED  
WHEN SIGNED DRAWING AND  
CONFIRMED ORDER ARE RECEIVED.

SIGNATURE: \_\_\_\_\_

DATE: \_\_\_\_\_

\*All pages of this Schedule A are incorporated by  
reference and are a part of the additional terms of  
the Master Terms & Conditions of Sale.  
www.newberrytanks.com/masterterms.pdf

SALES ORDER: -

**Newberry Tanks**  
New Thinking

Phone: 870-735-4473

WEIGHT (LBS): **1490**

All units inches  
unless stated  
otherwise

DESCRIPTION:  
750 GALLON RECTANGULAR UL 142 DOUBLE WALL TANK

CUSTOMER: \_\_\_\_\_ P.O.# \_\_\_\_\_

DATE: 3/7/2023 SCALE: \_\_\_\_\_ DWG.# FTDBS-0750

DRAWN BY: AJC  
CHKD BY: \_\_\_\_\_