

**PLAN VIEW**

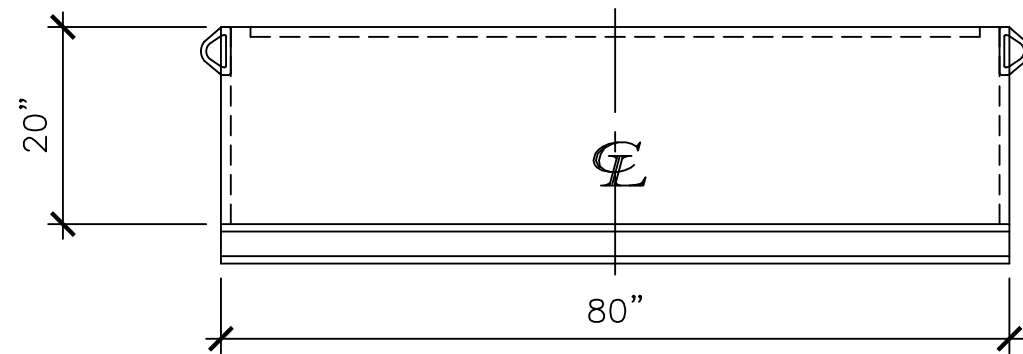

**FRONT VIEW**

ITEM	QTY	DESCRIPTION
A	1	2" WELD FLANGE (DRAIN)
B	4	LIFTING LUG
C	2	W4 x 13# x 80"

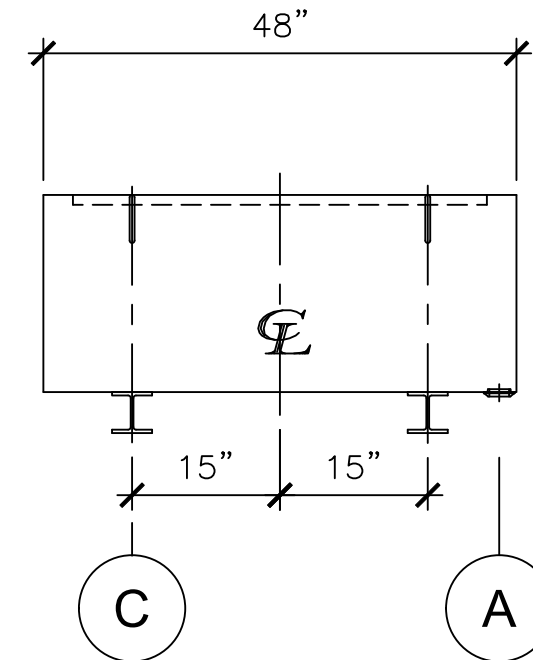

**RIGHT SIDE**

**NOTES:**

- A. Material: H.R. Carbon Steel.
- B. Exterior: One coat gray primer.

APPROVAL FOR CONSTRUCTION SCHEDULE A - MASTER TERMS & CONDITION OF SALE*		SALES ORDER: -		WEIGHT (LBS): 520	
<input type="checkbox"/> APPROVED AS DRAWN.		 All units inches unless stated otherwise Phone: 870-735-4473			
<input type="checkbox"/> APPROVED WITH NOTED CHANGES. CONSTRUCTION WILL BE SCHEDULED WHEN SIGNED DRAWING AND CONFIRMED ORDER ARE RECEIVED.					
SIGNATURE: _____		DESCRIPTION: Containment Dike For 300 Gallon Tank			
DATE: _____		CUSTOMER: -		P.O.#: -	
<small>*All pages of this Schedule A are incorporated by reference and are a part of the additional terms of the Master Terms &amp; Conditions of Sale. www.newberrytanks.com/masterterms.pdf</small>		DATE: 03/13/23	SCALE:	DWG.# NB00300CNT04820	DRAWN BY: WR
SHEET 1 OF 1					